

# OPERATOR'S MANUAL

## **TXM-15** Manual Cold Meat Press

**doughXpress.**

HIX® CORPORATION COMMERCIAL FOOD DIVISION



For Customer Service:  
Call 1-800-835-0606 or Visit [hixcorp.com](http://hixcorp.com)

**HIX** CORPORATION



# CONTENTS

<i>Receiving &amp; Setup</i> .....	3
<i>Operation</i> .....	3
<i>Cleaning</i> .....	3
<i>Parts List</i> .....	4
<i>Warranty</i> .....	6

BEFORE warranty repair you MUST get Prior Authorization



# RECEIVING & SETUP

## UNPACKING

Remember to save all packing materials - including any crating, boxes, liners, and boards. You may need these for shipping your machine or should a repair be necessary in the future.

## INSPECTION

Inspect your machine for hidden shipping damage. Contact the delivery company immediately, should you find damage.

## PLATEN SURFACE

Slight surface imperfections are a normal part of the aluminum casting process for the platens on your press. These are not considered a defect and do not affect the functionality of the machine in any way.

**NOTE:** Upon receiving your new equipment, some debris or residue may be present on the aluminum platen(s). Clean the platens per the instructions provided prior to first use.

# OPERATION

1. With the press in the open position, adjust the press to the desired thickness by turning the thickness control knob located on the top of the machine. Thickness is reduced by turning the knob **clockwise** and increased by turning it **counterclockwise**. Using the thickness control knob, turn left for thicker or right for thinner until you have the thickness you desire.  
**CAUTION: DO NOT OPERATE THIS PRESS WITH ANY OTHER PERSON(S) / HAND(S) NEAR YOU OR THE PRESS. SERIOUS INJURY COULD RESULT.**
2. Pull down the handle all the way, applying pressure, until it stops. Raise the handle all the way up.
3. Rotate the upper platen away and remove your flattened product.

# CLEANING

## CLEANING THE PLATENS

1. Open the press for easier access
2. Clean the platen(s) with a mild soap and warm water applied with a soft cloth or sponge. Do not use steel wool, scrub sponges, kitchen or oven cleaners, or any other kind of abrasive material. This will damage the platen.
3. Wipe clean with a dry cloth.

## CLEANING OUTSIDE SURFACES OF THE MACHINE

Use a mild soap and warm water applied with a soft cloth or sponge. Do not use steel wool, scrub sponges, kitchen or oven cleaners, or other abrasives that will damage the surface.

## LUBRICATION

Your press requires lubrication every 15,000 cycles, or every 6 months. Lubricate weekly in a heavy use production environment. Use NSF/NLG12 rated food grade grease (such as Bel-Ray No-Tox #2 or equivalent). A general purpose food grade machine oil spray is also acceptable such as CRC03055 lubricant (available from retailers such as Amazon). Lubricate all moving or hinged points.

# REPLACEMENT PARTS LIST

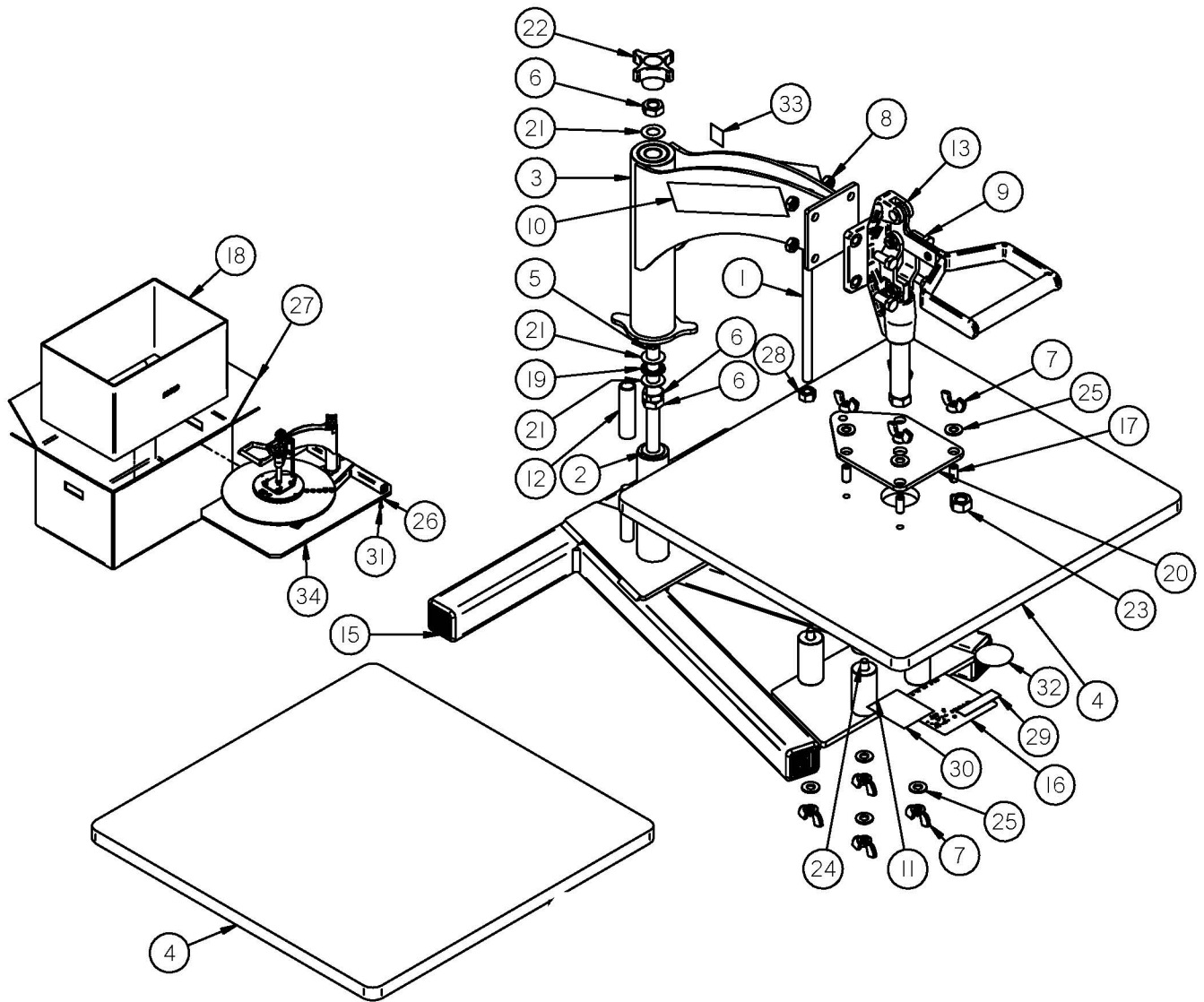

# REPLACEMENT PARTS LIST

ITEM#	PART#	TITLE	ITEM#	PART#	TITLE
1	9152500	M-TXM15 ANTI ROTATION BOLT			
2	9151002	TXM-15 CP FRAME WELDMENT			
3	9150030	TXM15 PIVOT ARM WELDMENT CURVED			
4	9141500	TXM-15 CP LOWER PLATEN			
5	9141010	SWG15 PRESSURE ADJ ROD			
6	87056	NUT 1/2-13 JAM			
7	84806	NUT WING 5/16-18 ZPS			
8	71662	NUT 5/16-18 JAM NYLON INSERT ZPS			
9	71498	BOLT 5/16-18x0.750 G8			
10*	71011	M-DECAL DOUGHXPRESS			
11	7051500	DD LWR PLATEN SPACER			
12	7051035	TXM15 MAIN ARM STOP SLEEVE			
13	70426	CLAMP TOGGLE TXM15 SHOVEL DIP			
14*	70359	MANUAL OWNERS TXM-15 CP			
15	70283	PLUG TUBE 1.5x1.5x.120 BLK			
16	70268	DECAL HIX I.D. 3" X 3" SILVER			
17	65935	SCREW SET 5/16-18x0.750 ZP			
18	63886	BOXHT SWINGMAN LINER			
19	63622	BEARING THRUST .500x0.937x.078			
20	63584	SWG15 PLATEN MNT PLATE			
21	63320	BEARING WSHR .500x0.937x.031			
22	62898	KNOB PHENOLIC SWINGMAN			
23	37214	NUT M12x1.75 ZPS			
24	25434	SCREW SET 5/16-18x3.000			
25	24732	WASHER FLT .344X0.688X.063 ZPS			
26	16683	WASHER FLT .375x0.875x.078 ZPS			
27	14907	BOXHT PRESTO 15 BOX			
28	14571	NUT 3/8-16 ZPS			
29	11434	DECAL, FOR SERVICE 2 X .5			
30	10963	DECAL, QR CODE DXP			
31	10769	BOLT 5/16-18x1.000			
32	10664	DECAL MADE IN USA			
33	10550	DECAL THICK THIN			
34	0101013	SWINGMAN 15 MOUNTING BOARD			

# WARRANTY

**BEFORE warranty repair you MUST get Prior Authorization: Call 1-800-835-0606 Warranty will be voided otherwise.**

doughXpress® will automatically register the equipment on the date it was shipped to you or your distributor. If the equipment was not purchased directly from HIX, but through a distributor (either domestic or foreign), please keep a copy of their sales invoice showing the serial number and date it was sold/shipped to you with this warranty.

In this case, we will use the distributor's invoice date as the beginning warranty date. **STAPLE A COPY OF YOUR RECEIPT TO THIS WARRANTY** and keep in a safe place to provide verification of your warranty should a problem occur. Thank you.

Please fill in the following information and attach a copy of your receipt for your records.

**Date Purchased:** \_\_\_\_\_ **From:** \_\_\_\_\_  
**Model #:** \_\_\_\_\_ **Serial #:** \_\_\_\_\_

This warranty applies to equipment manufactured by the HIX Corporation (HIX), Pittsburg, Kansas, U.S.A. HIX warrants to the original purchaser, the full line of doughXpress® product against defects in workmanship and material, except for wear and tear for a period of one year parts and labor limited warranty on most items, there are selected items which may carry a two year warranty (refer to owners manual.) All dough press carts, compressors, and accessories are warranted for 90 days from the date of purchase. Repairs include parts and labor only, excluding is the following:

1. Overtime Labor Rates
2. Expedited Freight for Parts
3. doughXpress® assumes no responsibility for down time or loss of product. All defective parts must be returned to doughXpress® for credit. Repairs must be pre-authorized by doughXpress® prior to work commencing.
4. Travel time is not covered by doughXpress®, unless pre-authorized by doughXpress®. In the event of a defect, doughXpress®, at its option, will repair, replace or substitute the defective item at no cost during this period subject to the limitations of insurance and shipping costs stated below.

This warranty does not cover normal wear and tear, damages due to accident, misuse/abuse, alterations or damage due to neglect, or lack of proper lubrication or maintenance. doughXpress® shall not be responsible for repairs or alterations made by any person without the prior written authorization by doughXpress®. This warranty is the sole and exclusive warranty of doughXpress® and no person, agent, distributor, or dealer of doughXpress® is authorized to change, amend or modify the terms set forth herein, in whole or in part.

In the case of a problem with the equipment identified herein, doughXpress® should be contacted during regular business hours to discuss the problem and verify an existing warranty. doughXpress® personnel will assist the customer to correct any problems which can be corrected through operation or maintenance instructions, simple mechanical adjustments, or replacement of parts. In the event the problem cannot be corrected by phone, and upon the issuance of a return authorization by doughXpress®, the equipment shall be returned to doughXpress® or an authorized service representative. All insurance, packaging and shipment/freight costs are solely the responsibility of the customer, and doughXpress® shall not be responsible for improper handling or damage in transit.

doughXpress® customer service personnel may be contacted for complete return authorization and reconditioning information. This expressed warranty is given in lieu of any and all other warranties, whether expressed or implied, including but not limited to those of merchantability and fitness for a particular purpose, and constitutes the only warranty made by doughXpress®. In no event shall doughXpress®' liability for breach of warranty extend beyond the obligation to repair or replace the nonconforming goods. doughXpress® shall not be liable for any other damages, either incidental or consequential, or the action as brought in contract, negligence or otherwise.

This warranty gives you specific legal rights and you may also have other rights which vary from state to state.



1201 E. 27th Terrace • Pittsburg, KS 66762 • U.S.A.

Phone: (800) 835-0606 • Fax: 620-231-1598

Web site: [hixcorp.com](http://hixcorp.com) • E-Mail: [sales@hixcorp.com](mailto:sales@hixcorp.com)