

TT-180D

Fluorescent Table Top Exposure Units

OWNER'S MANUAL



TT-180D shown



For Customer Service, Call **1-800-835-0606** or
Visit www.hixcorp.com

CONTENTS

Installation / Setup	2
Loading Screen	3
Expose Screen	5
Determining Exposure Time	5
Exposing Time Chart	6-7
Glass Cleaning	8
Bulb Replacement	8
Lid Realignment	9
Blanket Replacement	10
Troubleshooting	11
Warranty	12

BEFORE warranty repair you MUST get Prior Authorization:

RECEIVING & INSTALLATION

NOTE: The HIX TT-180D is not compatible with the M&R Trilok pin registration system.”

CAUTION: Before installing or operating the unit be sure to read these instructions thoroughly. Disconnect all electric power before performing maintenance on the unit. **Never** operate this equipment with the power supply cover removed. If you find that this should be necessary, contact a licensed electrician. Make sure the circuit for this unit is well grounded.

WARNING: ULTRA VIOLET LIGHT CAN CAUSE SKIN AND EYE IRRITATION OR BLINDNESS. TO PREVENT DAMAGE TO YOUR EYES AND SKIN, AVOID DIRECT EXPOSURE TO THE LAMP WHILE IT IS ON.

INSTALLATION

1. Carefully uncrate exposure unit from its shipping container.
2. Place exposure unit on a level surface close to the wall circuit to be used.

WARNING: When using an extension cord, use 14 ga.-3 conductor. Maximum length, 25' (7.62m).

3. Check unit over for any transportation damage and make sure all foreign objects, such as packing material, have been removed. Clean top side of glass to remove any dust.
4. Remove vacuum pump from shipping container. Be sure to read and follow all instructions included with the pump, especially filling the pump with the supplied oil before use.
5. Plug pump into receptacle located on the back of the TT-180 exposure unit. Be sure the voltage switch on the pump is set to the proper voltage for the unit (120v or 220v).
6. Connect vacuum hose on pump to fitting on the back right side of the exposure unit lid.

SETUP

1. Plug in your unit to your power source and turn on power switch.

OPERATION

WARNING: During operation, make sure the lid is latched on both sides to prevent UV light exposure to eyes or skin.

LOADING SCREEN / STARTING VACUUM

Maximum screen sizes:

23" x 31"

NOTE: Put the screen in the center of the glass. Keep at least 2" from any edge of the glass to prevent damage to the vacuum blanket rubber.

1. Raise the lid and place frame in center of glass, screen side down.

NOTE: When using wood frames with tape and staples, be sure to tape over tape and staples to prevent damage to glass.

2. Place bleeder cord inside frame as close to the frame side as possible.

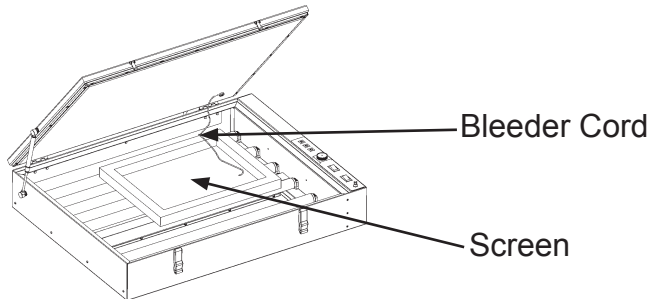

sible. (See illustration above) **NOTE:** This cord facilitates vacuum and releasing or draining off the vacuum after exposure.

3. Close lid and latch with the rubber latch-hooks.
4. Turn vacuum pump power switch "ON".
5. Check for proper draw down of blanket.

OPERATION

DIGITAL TIMER

1. Turn Main Power “On”. Timer will illuminate.



2. To change time setting, press the **◀** button on the front of the timer face. Timer will display “Minutes” and “Seconds”.
3. To program the desired number for the flashing column, press the **▲** button; once for each digit. The counter will loop from 0-9. To change to the next column, press the **◀** button and again press the button **▲** until the desired number is reached.
4. Once the new time is entered, press the “MD” button on the face of the timer to lock in this new setting. Failure to press the “MD” button will not “lock” in the new setting.
5. Press the “Start” button on the control panel. This will start the timer and turn the exposure lamp on.
6. Timer will count down and when time reaches zero, the exposure lamp will extinguish.
7. If at any time you want to extinguish the exposure lamp before time expires, you may do so by pressing the “RST” button on the face of the timer.

NOTE: Read your emulsions exposure instructions.

1. Set for the optimum exposing time for the screen you are going to expose. See “Determining Your Optimum Exposure Time” below or your filled in chart in this manual if you have already determined your exposing time.
2. Push start button to initiate your set exposure time.
3. At the end of the set exposure time as indicated by the timer beeping, you can turn off the power switch, remove the weighted board, rubber drape, foam block and the exposed scree

SCREEN EXPOSURE

DETERMINING YOUR OPTIMUM EXPOSURE TIME

NOTE: This procedure should be followed for each new emulsion type, new mesh count or mesh type (i.e. yellow, orange, white). This procedure should also be followed periodically since the bulb intensity will lessen with age.

Exposure Calculator (Preferred Method)

See your emulsion supplier for an exposure calculator and follow their instructions.

By Step Trial Method

Expose dried coated screen in 1 minute intervals as follows:

1. Place cardboard sheet between positive and glass leaving approximately 2" of positive exposed. After 1 minute, move cardboard approximately 2" more and now expose for 1 minute. Then move cardboard a 3rd time approximately 2" expose once again. Repeat at least to 4 minutes. Now you have 4 expose areas of 1, 2, 3 and 4 minutes.
2. Inspect your newly exposed screen for proper exposure.

Underexposed: results in weak stencil with poor emulsion adhesion and reduced resistance to printing inks and wash up solvents. **Overexposed:** results in loss of fine detail.

3. Once you have determined the proper exposure for your emulsion type fill in the chart provided at end of this manual as a ready reference. This will save you time in the future.

NOTE: This procedure should be followed for each new emulsion type, new mesh count or mesh type (i.e. yellow, orange, white). This procedure should also be followed periodically since the bulb intensity will lessen with age.

EXPOSURE TIMES

Use and copy this chart for recording your shop's popular emulsions and exposure times.

OPTIMUM EXPOSING TIME CHART

DATE	MESH COUNT	EMULSION COLOR	EMULSION BRAND	COATING METHOD	EXPOSURE TIME

EXPOSURE TIMES

Use and copy this chart for recording your shop's popular emulsions and exposure times.

OPTIMUM EXPOSING TIME CHART

DATE	MESH COUNT	EMULSION COLOR	EMULSION BRAND	COATING METHOD	EXPOSURE TIME

MAINTENANCE

GLASS CLEANING OR BULB REPLACEMENT

In order to maintain short exposure times, keep the unit's exposure glass clean. Dusting is usually sufficient. If more cleaning is required use a soft cloth moistened with alcohol. A dusty environment will require more cleaning.

When you notice your exposure times getting longer or if the lamp fails to operate, check the Troubleshooting Chart.

To clean back side of glass or replace bulbs:

1. Carefully lift front of glass from the gasket (leave back of glass resting on its gasket).

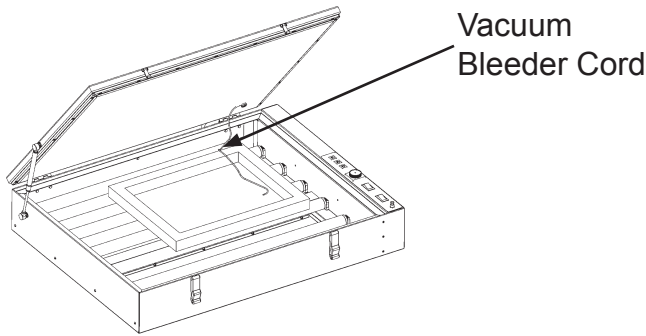

2. Remove old bulb, Insert new bulb.
3. Carefully replace the glass as it was before.
4. Clean underside and lay back down carefully.

WARNING: To lift glass use flexible (non rigid) item such as putty knife. If you lift the glass, do so carefully so as to not scratch or break the glass. Never use a screwdriver.

VACUUM PUMP MAINTENANCE

It is recommended to change the vacuum pump oil after 50 hours of usage. The purity of the oil will determine the final vacuum level achieved. Always use the CPS recommended vacuum pump oil (VPOQ/VPOP/VPOG). The oil provided with the pump has been specially blended to maintain maximum viscosity at normal running temperatures as well as cold weather starts.

OIL CHANGE PROCEDURES:

1. Be sure the pump oil is warmed up. If not warm, turn vacuum pump "ON" for 10 minutes.

REPAIRS

2. Make sure vacuum pump is not plugged in.
3. Remove the oil drain cap and drain the contaminated oil into a suitable container. Tilt the vacuum pump toward the oil drain port.
4. Once all the oil has been drained, re-secure the oil drain cap back onto the oil drain port.
5. Remove the exhaust/oil fill cap and add oil until it is seen in the middle of the oil sight glass. Re-secure exhaust/oil fill cap.

LID REALIGNMENT

NOTE: The vacuum is sealed under the lid by means of rubber gasket under the lid frame. This rubber gasket may compress over time. If the vacuum does not occur, the rubber gasket may be compressed. These problems can be alleviated by lowering the hinges.

CAUTION: It is important to do this operation with the lid up, failing to do so could cause injury due to the sudden release of pressure on the gas spring!

1. Fully open the lid.
2. Using a pencil, tape, or other suitable indicator, place a mark on the frame of the unit corresponding with a mark on the lower leaf of the hinges.
3. Using a 9/16" wrench, loosen the four bolts fastening the lower leaf of the hinges.
4. Let each hinge drop approximately 1/16" using the indicator placed on the hinge in step 2.
5. Tighten all four bolts securely and test unit. If this does not work repeat this process and drop the hinges another 1/16"

Warning: Lowering the hinges too much can place excess pressure on the glass and frame of the unit and should be avoided. If the lid is difficult to close or does not stay closed under its own weight, the hinges should be raised.

NOTE: If the blanket fails to pull a vacuum, check the Troubleshooting Chart for possible causes. If you determine that your blanket has begun to leak, it needs to be replaced. New blanket material can be ordered from HIX Corporation.

REPAIRS

NOTE: Mark from which side the aluminum strips were located so that they can be replaced in the same location.

1. Begin with the lid in the open position. Remove the plastic cap from the lid end of one of the gas springs. While holding the lid, pull the end of the gas spring straight out and off of the ball connector as you continue to manually hold the lid up.

Caution: It is important to do this operation with the lid up, failing to do so could cause injury due to the sudden release of pressure on the gas spring!

2. Remove the vacuum hose from the lid.
3. Gently lay lid back down onto glass. Using two 9/16" wrenches, remove the 4 nuts and bolts holding the lid to the hinges.
4. Remove the entire lid assembly from the frame and lay upside down on a flat surface.
5. Mark from which side of the aluminum strips were located so that they can be replaced in the same location.
6. Remove all screws from the aluminum strips.
7. Remove the blanket material and any adhesive still attached to the lid frame.
8. Lay new blanket material across the lid in the proper orientation allowing the material to sag down to your working surface.
9. Seal the rubber to the blanket frame with the included adhesive.
10. Replace the aluminum strips on the same side that they were removed. Tighten all screws securely. Caution: over tightening screws may strip the threads in the lid frame.
11. Trim any excess blanket material by running a sharp utility knife along the outside of the aluminum frame.

TROUBLESHOOTING

<i>PROBLEM</i>	<i>POSSIBLE CAUSE</i>	<i>REMEDY</i>
Bulbs do not come on and red light on main power switch is off	No line power Supply fuse or breaker blown Unit main breaker is blown Main power switch is defective Outlet is defective	Check power source Reset supply breaker or replace fuse Reset unit's main breaker Replace switch Replace outlet
Bulbs do not come on and red light on main power switch is on	Bulbs are burned out Ballast is bad	Replace Bulbs Replace Ballast
Unit blows fuses or trips Main Power Circuit Breaker	Check amperage of supply breakers or fuses Shorted ballast	Replace supply breakers or fuses with minimum rating of 15 amps Replace ballast
Lamp fails to remain ignited	Bad Lamp Bad Ballast	Replace Lamp Replace Ballast
Blanket won't "pull" a vacuum	Vacuum leak Clean Residue off seal	Check hose connections to vacuum pump and to blanket frame. Check gasket to glass seal, replace if necessary. Realign lid. Check vacuum pump.
Longer Exposure Times	Dirty Glass Worn Out Blubs	Clean front or back of glass. Replace <u>ALL</u> bulbs.

WARRANTY

(Effective October 30, 2015)

HIX will automatically register the equipment on the date it was shipped to you or your distributor. If the equipment was not purchased directly from HIX, but through a distributor (either domestic or foreign), please keep a copy of their sales invoice showing the serial number and date it was sold/shipped to you with this warranty. In this case, we will use the distributor's invoice date as the beginning warranty date. **STAPLE A COPY OF YOUR RECEIPT TO THIS WARRANTY** and keep in a safe place to provide verification of your warranty should a problem occur. Thank you.

Please fill in the following information and attach a copy of your receipt for your records.

Date Purchased: _____ From: _____

Model #: _____ Serial #: _____

This warranty applies to equipment manufactured by the HIX Corporation (HIX), Pittsburg, Kansas, U.S.A. HIX warrants to the original purchaser, its Ovens and Dryers, Heat Transfer Presses, Mug Presses, Mug Glazer, Retensionable Screen Frames, Textile Printers, Spot Heaters, and Exposure Units against defects in workmanship and material, except for wear and tear for a period of "One Year" from the date of purchase. HIX warrants its Accessories, Reten Splines/Hardware/Tool Kit, and Shuttle for a period of 90 days from the date of purchase. Thermatrol and doughXpress products are covered under separate warranty.

In the event of a defect, HIX, at its option, will repair, replace or substitute the defective item at no cost during this period subject to the limitations of insurance and shipping costs stated below.

In the case of heat transfer presses (except the Hobby Lite), HIX warrants the heat casting for the "Life" of the machine for the original purchaser. If a part becomes obsolete at the time for repair, and/or cannot be reasonably substituted for, HIX will credit, at half the then current list price or last recorded price, only that part toward a new machine or any product HIX offers. This credit offer shall be the sole responsibility of the HIX Corporation in the event of an obsolete part.

This warranty does not cover belts, rail tape, pads, mug wraps, canvas, rubber blankets, bulbs, glass, rod ends, turn buckles on printers or damages due to accident, misuse/abuse, alterations or damage due to neglect, shipping or lack of proper lubrication or maintenance. HIX shall not be responsible for repairs or alterations made by any person without the prior written authorization by HIX. This warranty is the sole and exclusive warranty of HIX and no person, agent, distributor, or dealer of HIX is authorized to change, amend or modify the terms set forth herein, in whole or in part.

In the case of a problem with the equipment identified herein, HIX Corporation should be contacted during regular business hours to discuss the problem and verify an existing warranty. HIX personnel will assist the customer to correct any problems which can be corrected through operation or maintenance instructions, simple mechanical adjustments, or replacement of parts. In the event the problem cannot be corrected by phone, and upon the issuance of a return authorization by HIX, the equipment shall be returned to HIX or an authorized service representative. All insurance, packaging and shipment/freight costs are solely the responsibility of the customer, and not that of HIX, and HIX shall not be responsible for improper packaging, handling or damage in transit. Contact HIX customer service for complete return authorization information. Correct shipping boxes are available from HIX.

This expressed warranty is given in lieu of any and all other warranties, whether expressed or implied, including but not limited to those of merchantability and fitness for a particular purpose, and constitutes the only warranty made by HIX Corporation.

In no event shall HIX's liability for breach of warranty extend beyond the obligation to repair or replace the nonconforming goods. HIX shall not be liable for any other damages, either incidental or consequential, or the action as brought in contract, negligence or otherwise.

This warranty gives you specific legal rights and you may also have other rights which vary from state to state.



Design and Manufacturers of Graphic Imaging, Commercial Food, Industrial and Custom Drying Equipment

1201 E. 27th Terrace • Pittsburg, KS 66762 • U.S.A.

Web site: www.hixcorp.com • Phone: (800) 835-0606 • Fax: 620-231-1598

E-Mail: customerservice@hixcorp.com • E-Mail: sales@hixcorp.com